

SS264N Pair

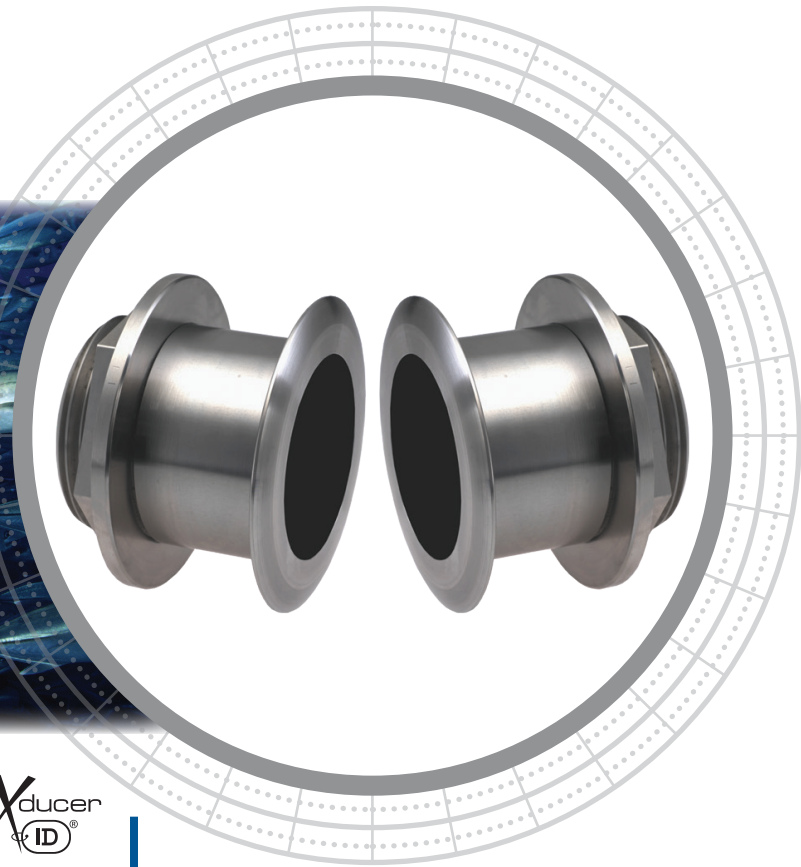

Two Eyes for Your Fishing

Legendary B260 1 kW performance is now available for fast sportfishing boats. No fairing required! Airmar has taken the proven B260 thru-hull and split it apart into a pair of tilted-element transducers. The ceramic elements have been tilted to offset for the deadrise of your boat's hull. Called the SS264N Pair, these transducers are perfect for fast, center-console, and trailered sportfishing boats, or any vessel that cannot have a thru-hull with a High-Performance Fairing.

Narrow and Wide

The narrow-beam 200 kHz transducer will give you excellent resolution and crisp image detail needed for bottom fishing. The low ringing of this transducer is perfect for finding fish holding tight to the bottom and other structure. The seven-element 50 kHz transducer is the same as in the SS264W and is best for deep-water sounding down to 914 m (3,000').

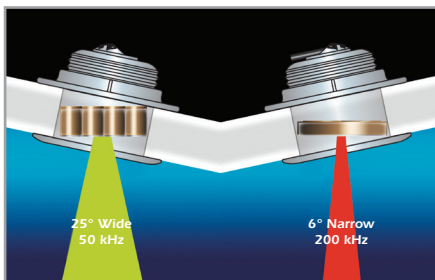

The high-performance ceramic elements are tilted inside the housing, which compensates for your boat's deadrise. This aims the beams straight toward the bottom, resulting in stronger echo returns and more accurate depth readings.

Tilted Element™ Pair Thru-Hull Narrow-Beam 1 kW

Fishing Applications

- Blue-water trolling using 50 kHz
- Deep-water bottom and wreck fishing up to 800 m (2,625')

Features

- Consists of two transducers (purchased separately):
 - SS264 50 kHz wide-beam 25°
 - SS264 200 kHz narrow-beam 6°
- Transducers must be purchased separately for dual-frequency operation or individually as a single-frequency unit
- Fixed 20° tilted version for 16° to 24° hull deadrise
- Fixed 12° tilted version for 8° to 15° hull deadrise
- Low-profile protrusion below the hull
- No affect on your boats running performance
- Depth and fast-response water-temperature sensor
- Boat Size: 8 m to 11 m (25' to 35')



Sensing Technology

SS264N Pair

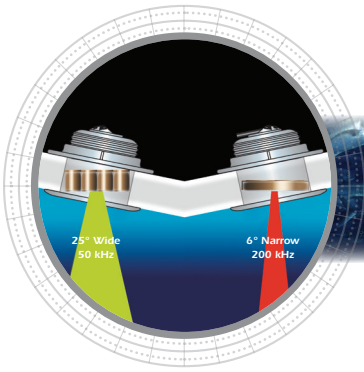

Technical Information

50 kHz-AWIq / 200 kHz-BH

Number of Elements and Configuration		
Beamwidth (@-3 dB)	25°	6°
RMS Power (W)	1 kW	1 kW
TVR	161 dB	175 dB
RVR	-175 dB	-183 dB
FOM	-19 dB	-10 dB
Q	4	8
Impedance	250 Ω	90 Ω

MAXIMUM DEPTH RANGE

50 kHz	200 kHz
400 m to 610 m (1,350' to 2,000')	206 m to 294 m (700' to 1,000')

BEAM DIAMETER VS DEPTH

Depth	50 kHz	200 kHz
9 m (30')	3 m (10')	0.9 m (3')
30 m (100')	14 m (45')	3.3 m (11')
122 m (400')	55 m (180')	13 m (42')
305 m (1,000')	137 m (450')	32 m (105')

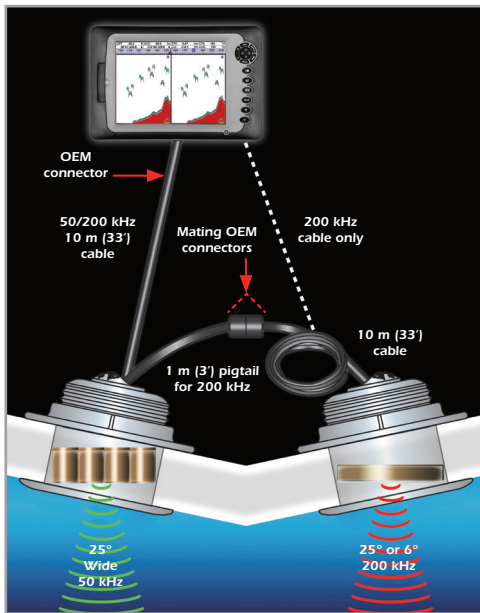

SS264N Pair wiring installation

SPECIFICATIONS

Weight: 2.7 kg (6 lb)
Hull Deadrise: Up to 24°
Acoustic Window: Urethane

DIMENSIONS

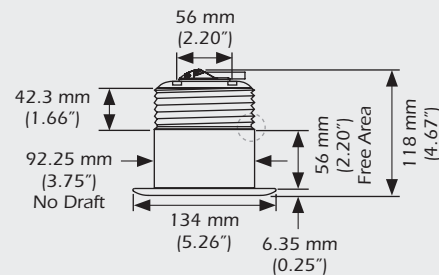
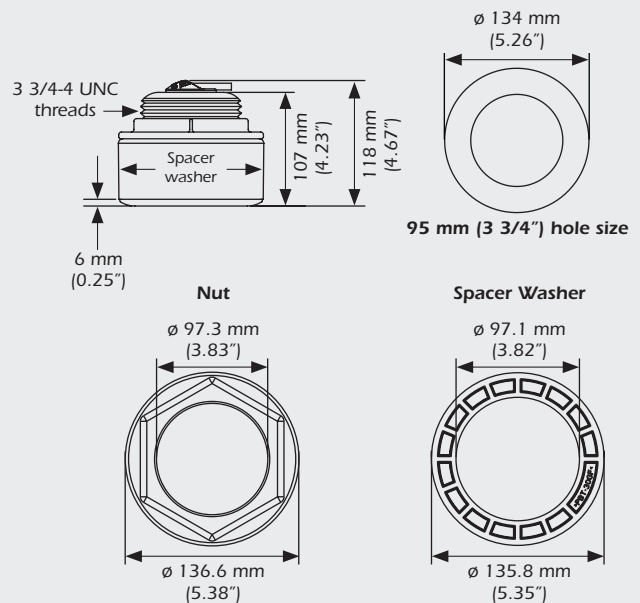

Directivity Patterns

