

Airmar ultrasonic transducers deliver the highest level of performance in the most challenging environments and they are the key component for our customers success and their applications. Our precision tuned air-ranging transducers are tried and true performers, even when used for difficult tasks. American-made from the highest quality materials, Airmar's ultrasonic transducers provide reliable, long-lasting excellence to any measurement system.

ATK120

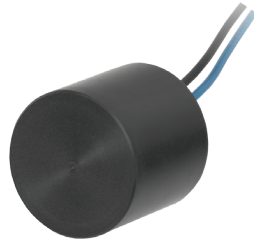

SPECIFICATIONS

Best Operating Frequency: 125 kHz, $\pm 4\%$
Minimum Transmit Sensitivity at Best Transmit Frequency: 102 dB re $1\mu\text{Pa}/\text{V}$ at 1 m
Minimum Receive Sensitivity at Best Receive Freq.: -172 dB re $1\text{V}/\mu\text{Pa}$
Minimum Parallel Resistance: 500 Ω , $\pm 30\%$
Minimum and Maximum Sensing Range*: 15 cm to 5 m
Typical Sensing Range: 20 cm to 3 m
Free (1 kHz) Capacitance: 1,000 pF, $\pm 20\%$ pF
Beamwidth (@ -3 dB Full Angle): 10° , $\pm 2^\circ$
Maximum Driving Voltage (2% Duty Cycle Tone Burst): 800 V_{pp}
Operating Temperature: -40°C to 90°C
Weight: 30 g
Housing Material: Kynar[®] 720
Acoustic Window: Kynar[®] 720

*Pulse-Echo Mode: Minimum and maximum ranges are best case scenarios. Actual range may vary, depending on drive circuitry and signal processing.

Note: Optimally, performance measurements should be taken when the transducer reaches a steady state.

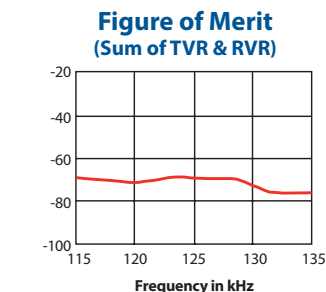
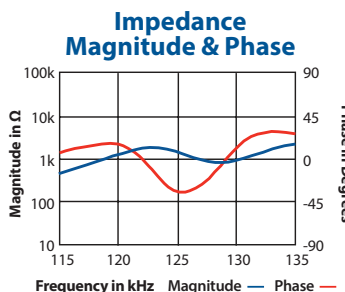
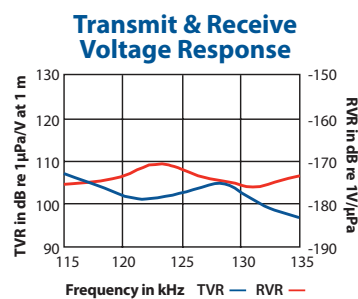
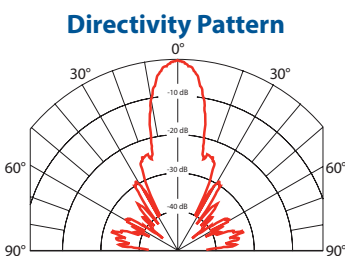

125 kHz AIRDUCER[®] Ultrasonic Transducer

Applications

- Level measurement in chemically aggressive environments
- Automation control
- Food and beverage processing
- Proximity sensing
- Obstacle avoidance

Features

- Rugged one-piece PVDF housing is U.S. FDA compliant
- Cylindrical design allows for installation in various applications

Options

- 10 K Ω thermistor available for temperature compensation
- Available in alternate housing (AT120)

Dimensions

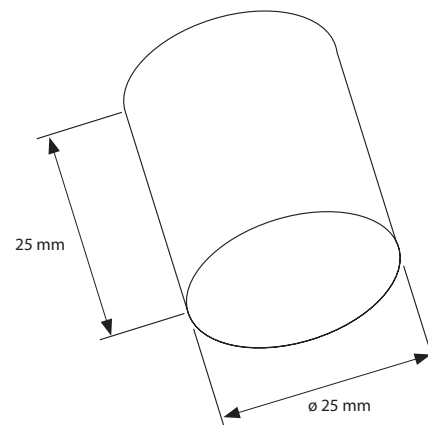

Additional Resources

Theory of Operations



Applying Ultrasonic Technology



T1 Developer Board



Airmar's T1 Developer's Transceiver Module can be used for evaluation of AIRDUCER[®] Transducers.