

Airmar ultrasonic transducers deliver the highest level of performance in the most challenging environments and they are the key component for our customers success and their applications. Our precision tuned air-ranging transducers are tried and true performers, even when used for difficult tasks. American-made from the highest quality materials, Airmar's ultrasonic transducers provide reliable, long-lasting excellence to any measurement system.

## 1 MHz – 29mm



## 1 MHz Ultrasonic Transducer

### Applications

- In-Pipe Flow Monitoring
- Open Channel Flow
- Wastewater Industry

### Features

- Robust PEEK Housing
- Low Profile
- Minimal Side Lobes

### Options

- M28 X 1.0 – 4g Threaded Housing

### Dimensions

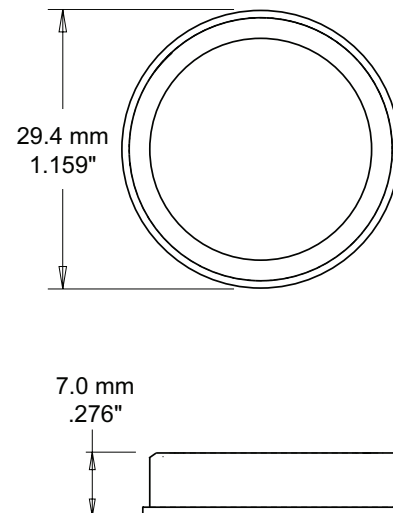

SPECIFICATIONS	
Nominal Operating Frequency:	1 MHz
Nominal TVR:	176
Nominal RVR:	-203
Q:	4
Minimum Parallel Resistance:	35Ω
Free (1kHz) Capacitance:	3500pF
Nominal Beam Width (@-3 dB Full Angle):	4°
Max Driving Voltage (2% Duty Cycle Tone Burst):	200V <sub>pp</sub>
Operating Temperature:	-20°C to 60°C
Weight:	10 g
Housing Material:	PEEK <sup>®</sup>
Acoustic Window:	PEEK

**Note:** Optimally, performance measurements should be taken when the transducer reaches a steady state.

### Technical Data

TVR in dB re 1μPa/Volt at 1 m  
RVR in dB re 1 Volt/μPa

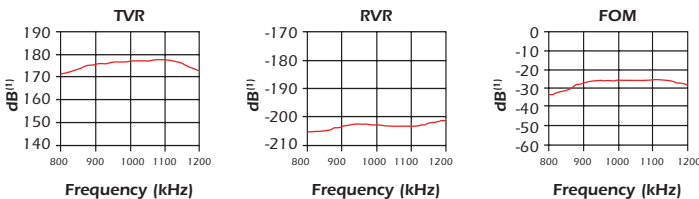

### Directivity Pattern

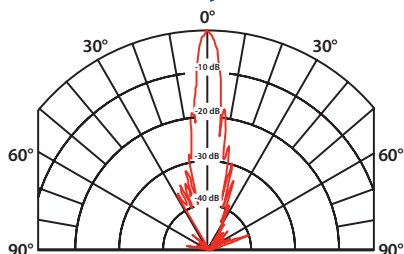

### Additional Resources

Theory of Operations



Applying Ultrasonic Technology



T1 Developer Board



Airmar's T1 Developer's Transceiver Module can be used for evaluation of 1 MHz Transducers.